

# Manual

## JLD-612 Temperature Controller



Figure 1.

### 1. Product Highlight

Thermocouple: T, R, J, B, S, K, E, Wre3-Wre25.

Thermo Resistor: Pt100, Cu50.

1 Relay output,

1 Relay output with PID, and

1 SSR output with PID to control external SSR.

Time proportional PID controlled output to either a Relay output or the SSR control output.

New built-in algorithms that to let you fine tune (Atdu) to fit most of control objects and various applications.

Temperature can be set to display in either Fahrenheit or Celsius.

### 2. Specifications

Operating supply voltage: AC20-265V or DC20-360V.

Power consumption:  $\leq 2$  Watt.

Sampling speed: 4/sec.

SSR activated voltage: open circuit: 8V; short circuit: 40mA.

Accuracy: 0.2% of full scale.

LED Display: 0.28 inch; Red color.

Out of range indication: "EEEE".

Ambient temperature requirement: 0~+50 Deg C.

Humidity requirement:  $\leq 85\%$  RH.

Relay Contact volume: AC220V / 3A.

Controller dimension: 48x48x82(mm).

Opening for installation: 45x45(mm).

### 3. Panel Illustrations and Descriptions



Figure 2.

- 1 -- AL1, relay J1 indicator.
- 2 -- AL2, relay J2 indicator.
- 3 -- AT, blanking during auto tuning process.
- 4 -- Out, output indicator.
- 5 -- Setting / Confirm.
- 6 -- Digit select / Auto tuning.
- 7 -- Select next parameter / value increment.
- 8 -- Selection previous parameter / value decrement.
- 9 -- Target value.
- 10-- Current value.

### 4. Parameter Setting

- i Press (SET) to enter setting mode, enter "0089", then press (SET) again.
- ii Press (v) and/or (^) and then (SET) to select parameters.
- iii Press (SET) to confirm entry or to select
- iv Press (^) to until "End" appear in red display to exit parameter setting loop.

#### a) Initialization parameter setting loop.

Table 1. Initialization Parameters:

| Symbol | Description                              | Range            | Default | Comment |
|--------|--|------------------|---------|---------|
| Inty   | Temp. sensor                             | See table 2      | Pt10.0  |         |
| Outy   | Method of controlled output              | 0,1,2            | 2       | Note 1  |
| Atdu   | AT skew                                  | 0-200            | 10      | Note 2  |
| PSb    | Temp sensor error correction coefficient | -1000~1000 deg C | 0       |         |
| Rd     | Heating=0;Cooling=1                      | 0,1              | 0       |         |
| CorF   | Celsius=0;Fahrenheit=1                   | 0,1              | 0       |         |
| End    | Exit                                     |                  |         |         |

Table 2. Temperature Sensor Type:

| Symbol | Description           | Range                          | Comment                 |
|--------|-----------------------|--------------------------------|-------------------------|
| T      | T Thermocouple        | -200 ~ 4000                    | Internal Resistant 100k |
| R      | R Thermocouple        | -50 ~ 1600                     | Internal Resistant 100k |
| J      | J Thermocouple        | -200 ~ 1200                    | Internal Resistant 100k |
| WRe    | WRe Thermocouple      | 0 ~ 2300                       | Internal Resistant 100k |
| B      | B Thermocouple        | 350 ~ 1800                     | Internal Resistant 100k |
| S      | S Thermocouple        | -50 ~ 1600                     | Internal Resistant 100k |
| K      | K Thermocouple        | -200 ~ 1300 C<br>-328 ~ 2372 F | Internal Resistant 100k |
| E      | E Thermocouple        | -200 ~ 900                     | Internal Resistant 100k |
| P10.0  | P100 Thermo Resistor  | -200.0 ~ 600.0                 | Constant Output 0.2mA   |
| P100   | Pt100 Thermo Resistor | -200 ~ 600                     | Constant Output 0.2mA   |
| Cu50   | Cu50 Thermo Resistor  | -50.0 ~ 150.0                  | Constant Output 0.2mA   |

**Note 1:**

0: Relay J1 and J2 as Alarm outputs; SSR Disabled, normally used for upper/lower limits alarm trigger control.

1: Relay J1 alarm output; Relay J2 PID controlled output and SV, AH2, AL2 values are not used; SSR control output disabled.

2: Relay J1 and J2 as alarm outputs; SSR PID controlled 8V output.

**Note 2:**

This controller has improved algorithms to prevent over calibration during auto-tuning. Atdu is the lower skew parameter during AT process.

Initiallization parameter setting

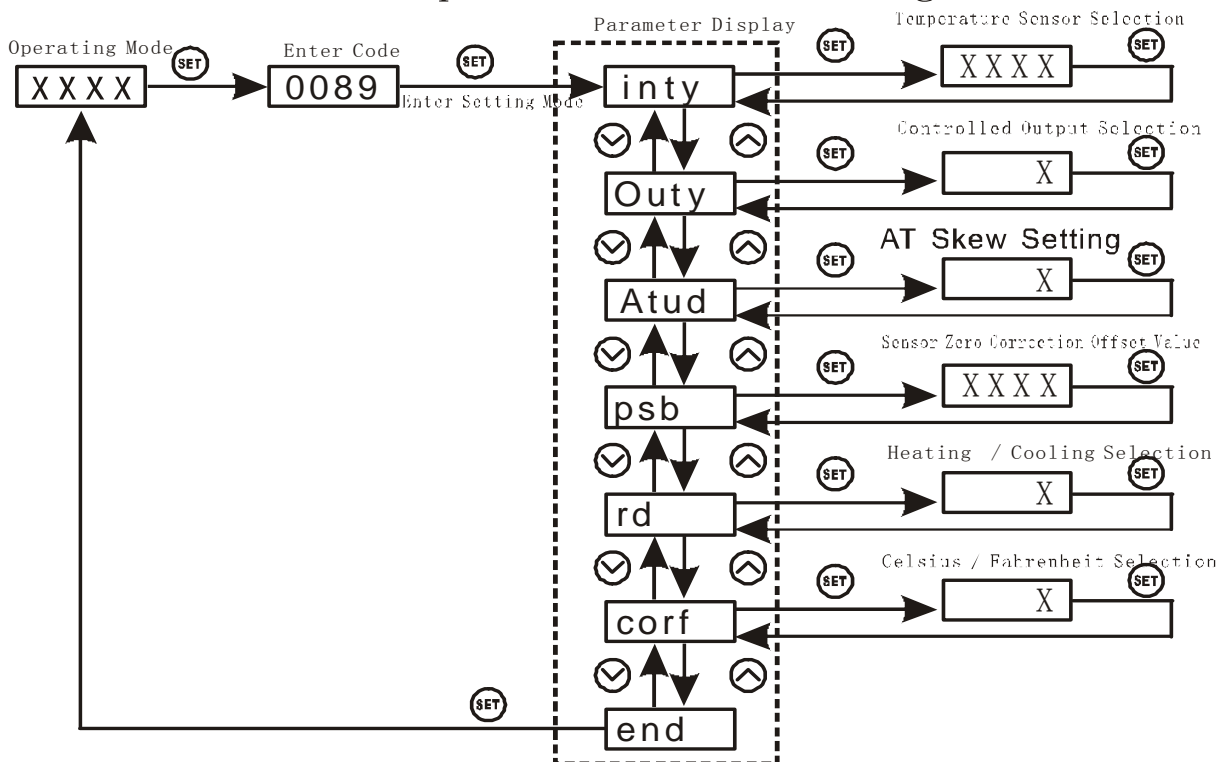

Figure 3.

b) To enter PID parameter setting mode press (SET), then enter code “0036”, press (SET) again.

Table 3. PID and Relevant Parameters:

| Symbol | Description                       | Range          | Default | Comment |
|--------|-----------------------------------|----------------|---------|---------|
| P      | Proportional Band                 | 0.1 ~ 99.9 (%) | 5.0     | Note 4  |
| I      | Integration Time                  | 2 ~ 1999 (Sec) | 100     | Note 5  |
| D      | Diffenciation Time                | 0 ~ 399 (Sec)  | 20      | Note 6  |
| SouF   | Overshoot Suppression Coefficient | 0.0 ~ 1.0      | 0.2     | Note 7  |
| Ot     | Control Period                    | 2 ~ 199 (Sec)  | 2       | Note 8  |
| Filt   | Digital Filtering Strength        | 0 ~ 3          | 0       | Note 9  |
| End    | Exit                              |                |         |         |

P,I and d parameters control the accuracy and respond time of the temperature controller. Auto-tuning is recommended for user who do not familiar PID control theory. P, I and d values should only be adjusted by professionals.

**Note 4**

Proportional Band (P): When P increases, fluctuation of object being controlled decreases. When P decreases, fluctuation of object being controlled increases. When P value is too small, system may become non-converge.

**Note 5**

Integration time (I): its purpose is to reduce static error. When I decrease, respond speed is faster but system is less stable. When I increase, respond speed is slower, but system is more stable.

**Note 6**

Differentiation time (d): its purpose is to control in advance and compensate delay. Setting d-value too small or too large would decrease system stability, oscillation or even non-converge.

**Note 7**

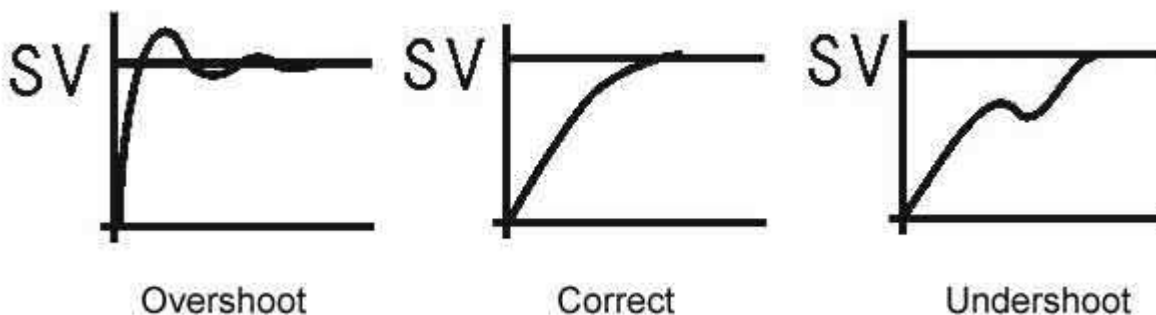

Overshoot suppression coefficient. When overshoot exists, increase SouF. When undershoot exists, decrease SouF.

**Note 8**

Control Period (ot): When ot gets smaller, heating/cooling cycle is driven faster, system respond speed is faster. But when using contact control (Relays), contacts wear out faster. When contact control (Relay) is used, normally set ot=5~15. When non-contact control (SSR) is used, normally set ot=2.

**Note 9**

Digital Filtering (Filt): Filt=0, filter disabled; Filt=1, weak filtering effect; Filt=3, strongest filtering effect; Stronger the filtering, more stable the readout, but has more readout display delay.

c) To enter temperature and alarm parameter setting mode press (SET), then enter code “0001”, press (SET) again.

Table 4. Temperature Setting and Alarm Related Parameters:

| Symbol | Description        | Range              | Default | Comment |
|--------|--------------------|--------------------|---------|---------|
| SV     | Target Temperature | With testing range | 80.0    |         |
| AH1    | Relay Closed       | With testing range | 80.0    |         |
| AL1    | Relay Opened       | With testing range | 90.0    |         |
| AH2    | Relay Closed       | With testing range | 80.0    |         |
| AL2    | Relay Opened       | With testing range | 90.0    |         |
| End    | Exit               |                    |         |         |

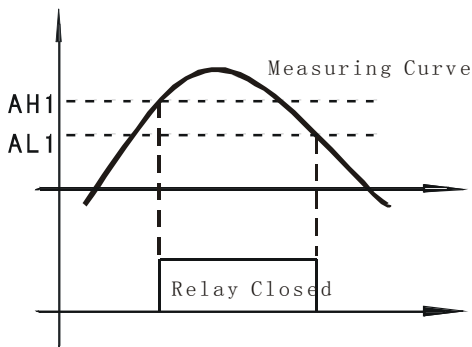

Figure 4

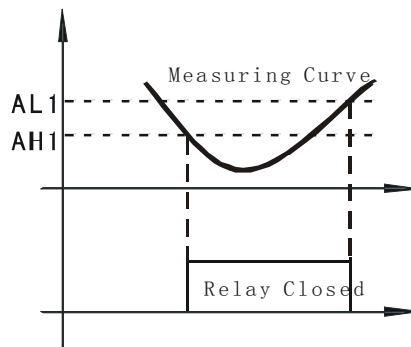

Figure 5

d) During Normal Operation mode, pressing (^) or (v), the display would show SV. Press (^) or (v) again increase or decrease SV by 1 degree.

a) Set AH1=AL1, relay is disabled.

b) Set AH1>AL1 (or AH2>AL2): Normally used for upper limit alarm trigger. See Figure 4.

c) Set AH1<AL1 (or AH2<AL2): Normally used for lower limit alarm trigger. See Figure 5.

**5. Auto-Tuning**

By simply press a single button the built-in artificial intelligent is activated to automatically calculate and set parameters (P,I,d,SouF,ot) that fit the condition to be controlled.

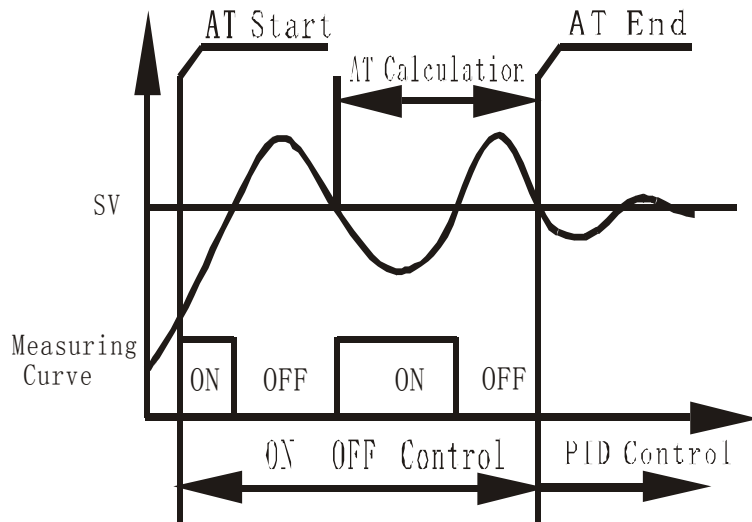

Figure 6.

a) How to Start and stop auto-tuning process:

- i. To activate auto-tuning, press and hold (>) until "AT" indicator blinks, which indicates auto-tuning is in progress. When auto-tuning finish, "AT" indicator is off. Now newly calculated PID parameters are remembered and start to be used.
- ii To EXIT during auto-tuning process, press and hold (>) until "AT" indicator turns off. Then previous PID parameters values are resumed.

## 6. Connection Terminals (back view).

Polarity of power at terminal 1 and 2 do not matter

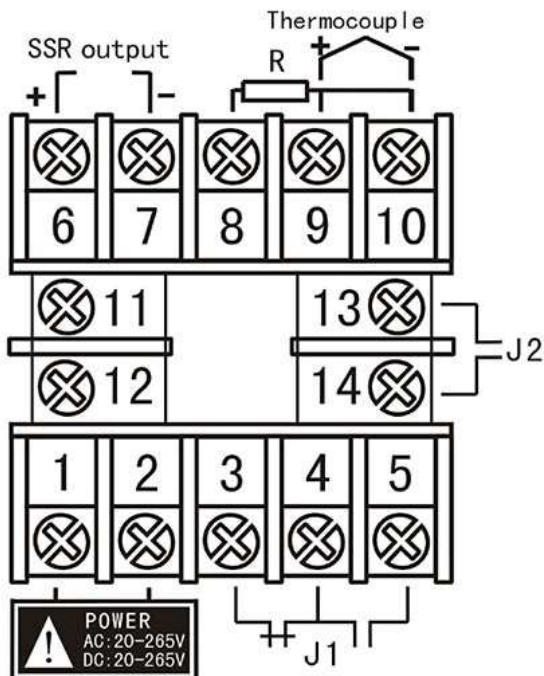

Figure 7.

## 7. Device Application Example

User want to control temperature (T) of furnace, 0 ~ 1000 deg Celsius sensor range is required. Furnace is to be maintained at 800 deg C. Alarm1 will go off if  $T > 850$  deg C, and

Alarm2 will go off if  $T < 750$  deg C. System power supply is AC110V. Installation opening is 45x45(mm). SSR will be used to control the heating element.

a) Choose VTC-620 with K-type thermocouple.

b) See figure for connection diagram.

c) Parameter setting:

|            |                  |
|------------|------------------|
| (Inty)=K;  | (SV)=800 deg C;  |
| (outy)=2;  | (AH1)=850 deg C; |
| (Atdu)=10; | (AL1)=848 deg C; |
| (psd)=0;   | (AH2)=750 deg C; |
| (rd)=0;    | (AL2)=752 deg C; |
| (CorF)=0;  |                  |

(auto-tuning is used to set PID parameters)

d) Power up the controller. Keep pressing (>) to activate auto-tuning. When "AT" stop blinking, new PID parameters are generated for the new system. The controller is in normal operation mode controlling the furnace temperature at 800 deg C.